



Installation Manual

STANDARD CONTROLLER

KDH-KS3024-IP



VERSION 4.0 29-03-2021



CONTENTS

1. Introduction.....	3
2. KDH-KS3024-IP controller technical data	4
3. General guidelines for controller installation	5
4. KDH-KS3024-IP controller module	6
5. Reader, exit button and sensor connection	7
6. Power supply, lock, Ethernet, door sensor and I/O module connection	8
7. APSAAT4 power supply for KDH-KS3024-IP controller	9
8. Controller module installation and connections in housing	10
9. Adding cards to controller memory without software	11

1. Introduction

KDH-KS3024-IP series standard controller is designed to be used in access control system, managed by **NMS ADVANCED CONTROL** software. Standard controllers (unlike integrated controllers) are made in the form of modules, placed in metal enclosure with power supply. They are located in the protected area. Other system components (readers, electric locks, buttons) are installed next to the controlled door and connected to the controller. Such solution guarantees higher system security level, compared to integrated controllers. Readers can use any identification technology, provided they adopt Wiegand 26-40 bit interface.

KDH-KS3024-IP model can handle:

- 2 door - two way
- 4 doors - one way

Models KDH-KS3012/24-IP have built-in IP ports for communication with NMS ADVANCED CONTROL software. Controllers are also provided with additional RS485 port, in order to connect extension module MOD3000INOUT.

List of the most important controller features and parameters is presented in attached table.

System capacity depends on software licence. Free version supports up to 8 controllers. To increase number of supported devices, proper licence purchase is needed.

It is possible to store up to 20000 cards in controller memory.

For each controller it is possible to connect KDH-MOD3000INOUT module, equipped with 4 relay outputs, 4 inputs and 4 transistor outputs, controlling buzzers in readers.

3000 series standard controllers, compatible with NMS ADVANCED CONTROL software.

Symbol	Controller description
KDH-KS3012-IP	Standard controller, 1 door - two way, 2 doors - one way, 2 readers ports, TCP port for communication and RS485 port for extension module, buffer for 20 000 cards, 50 000 events, 20 000 alarms
KDH-KS3024-IP	Standard controller, 2 door - two way, 4 doors - one way, 4 readers ports, TCP port for communication and RS485 port for extension module, buffer for 20 000 cards, 50 000 events, 20 000 alarms

2. KDH-KS3024-IP controller technical data

Parameter or function name	Parameter value - function description
Buffer capacity	
- Card buffer	20 000
- Event buffer - Alarm buffer	50 000 (auto delete of the oldest) 20 000 (auto delete of the oldest)
Electrical parameters	
- Supply voltage / Current load	12 VDC / 100 mA
Environmental parameters	
- Environment	For indoor installation only
- Operating temperature	-10°C do +55°C
- Relative humidity	10% - 90%
- Controller module size	140 x 175 mm (W x L)
- Cabinet with power supply size	350 x 304 x 91 (L x W x H)
Communication ports	
Direct PC connection	- TCP
Extension modules connection	- RS485 (dedicated port)
Readers & cards	
- readers ports	4 ports - Wiegand interface
- card formats	26 /34 bit Wiegand, self-defined
- card types	Compatible with reader technology
- keypad formats on readers	4-bits, without buffering
Inputs	
- door contact input	NO / NC - 4 inputs
- exit button input	NO / NC - 4 inputs
- general inputs	NO / NC - 4 inputs
- general inputs—on extension module	NO / NC - 4 inputs (option)
Outputs	
- electric lock control	Relay DC 12V 3A - 4 outputs
- general output	Relay DC 12V 3A - 1 output
- general output—on extension module	Relay DC 12V 3A - 4 outputs (option)
Access parameters	
- access levels	200
- schedules	200
- holidays (single or multiple-day periods)	80 x 64 days
Identification mode	Card, PIN, Card or PIN, Card + PIN
Alarm dismiss	Synchronize with input state or delay

3. General guidelines for controller installation

- Before controller installation please read this manual.
- Controller installation can be performed only by qualified personnel with the appropriate certificate, authorizing to install and service such equipment
- Controller should be installed **inside protected area** with temperature above +2°C and normal humidity.
- Controllers should be located so that the minimum distance from the cables and high voltage devices and other devices, that generate electrical noise, was 2 m. The minimum distance from the telephone line should be 1 m, and from transmitting devices 8 m.
- Controller should be powered from dedicated power supply, type APSAAT4, described in further part of manual
- Wire connections and works with internal controller parts with power on is strictly prohibited, as it may damage the device
- Before connecting controller to power supply, all necessary connections should be made, in accordance with this manual.

Connection wires table

Connection	Wire type	Distance
Ethernet switch (or router) > IP controller	UTP-5 twisted-pair wire with RJ45 connectors	Up to 50 m (recommended) (max. 100m)
KDH-MOD3000 module > Controller (located out of enclosure)	2 pairs of UTP-5 twisted-pair wire	Up to 800m (recommended) (max. 1200m)
Reader > Controller	6-core LIYCY 6x0,75 or UTP-5 twisted-pair wire	Up to 60m max.
Emergency exit button > Lock > Controller	2 or 4-core cable (4x1.0)	150m
Door contact > Controller	2-core cable (2x0.5)	150m
Exit button > Controller	2-core cable (2x0.5)	150m
Detector > Controller input	2-core cable (2x0.5)	150m
Mains power supply 230VAC	3-core cable (3x1.5)	-

4. KDH-KS3024-IP controller module

Control output for additional indicators
LED: POWER & RUN on enclosure cover (option)

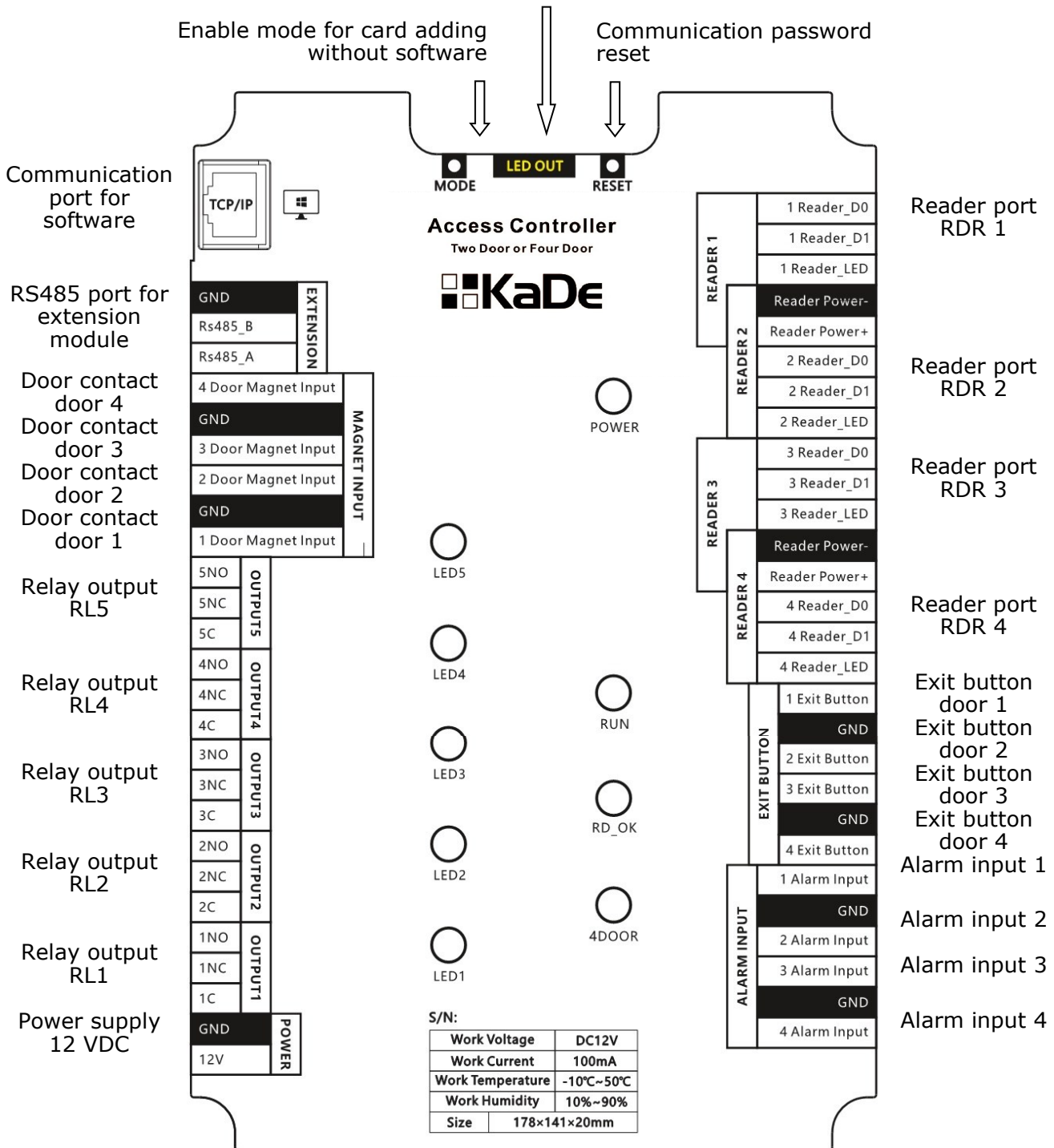

- Controller operating indicator
- Card reading indicator
- Two door control mode indicator

- Relay X switch indicator
- +12 VDC power supply indicator

5. Reader, exit button and sensor connection

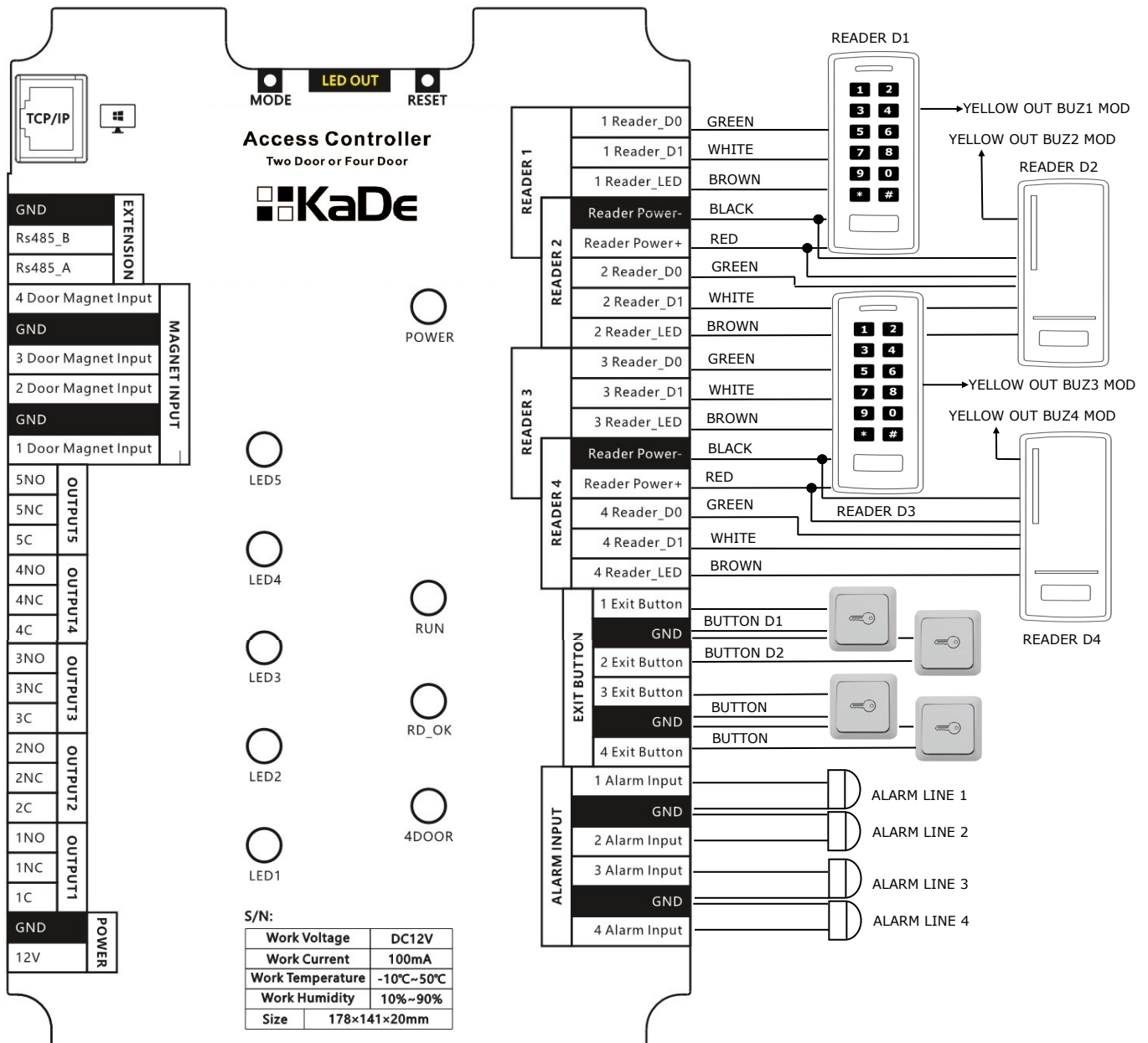

Function	Color	Czytnik 1	Czytnik 2	Czytnik 3	Czytnik 4
Power supply -	Black	1RD-	1RD-	2RD-	2RD-
Power supply +	Red	1RD+	1RD+	2RD+	2RD+
Wiegand D0	Green	1RD0	2RD0	3RD0	4RD0
Wiegand D1	White	1RD1	2RD1	3RD1	4RD1
LED	Brown	1LED	2LED	3LED	4LED
BUZ	Yellow	OUT BUZ1 MOD	OUT BUZ2 MOD	OUT BUZ3 MOD	OUT BUZ4 MOD

Notes: Connection between reader and controller: LIYCY type 6-core wire 6x0,75 (shielded) or twisted-pair UTP-5 (8-core)

Distance : between reader and controller ≤ 60m

Format: Wiegand format for reader, set in the software, needs to match reader's output format. Indicator of communication with reader: when user presents card to the reader, LED (RD_OK) on the controller module lights up—only, when connection with reader is correct and controller port works correctly. Otherwise, LED will not light up.

6. Power supply, lock, Ethernet, door sensor and I/O module connection

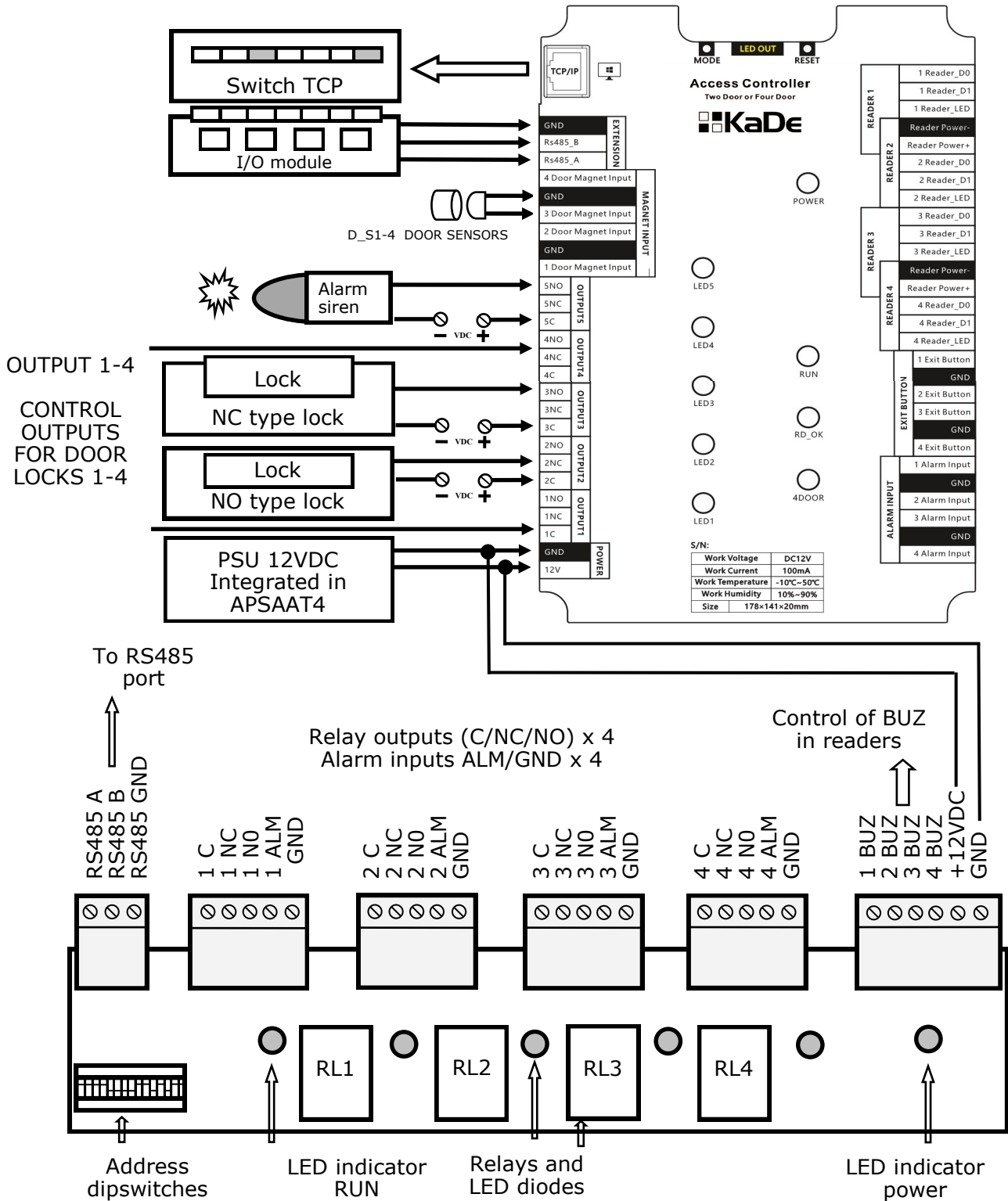

Extension module - KDH-MOD3000INOUT

Notes: Address dipswitches should be left at default settings (all ON). Present firmware of 3000 series controllers supports only one module. In future it will be possible to connect more modules, with different addresses, to one controller.

7. APSAAT4 power supply for KDH-KS3024-IP controller

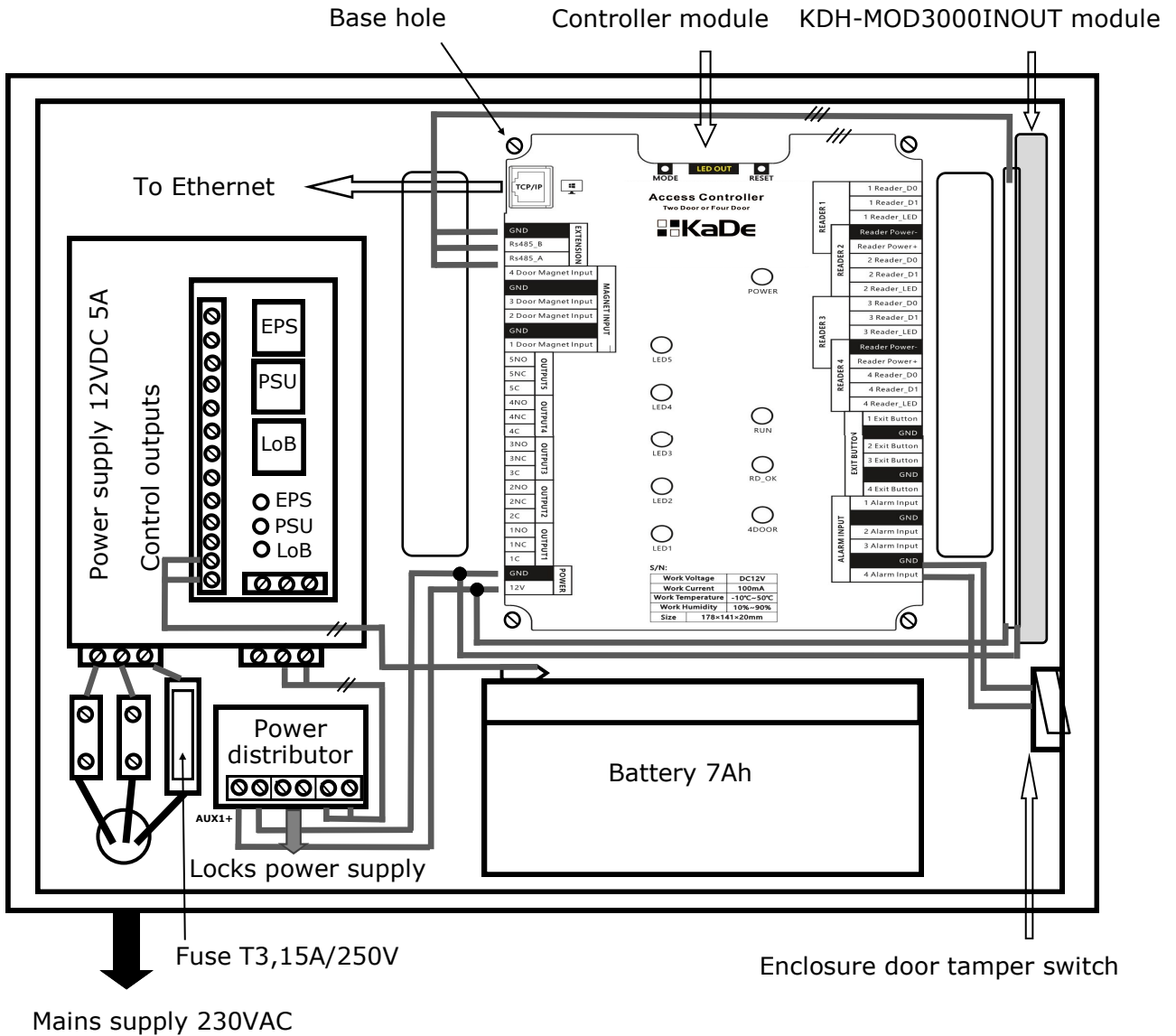

Power distributor

Provides two independent outputs, protected by polymer fuses:

- to controller and I/O module AUX1/COM - 0,9A, 13,8 VDC
- to locks, sirens AUX2/COM - 4A, 13,8 VDC

Control outputs - relay and transistor with LED indication:

EPS - technical output for absence of AC supply

PSU - output signalling absence of DC voltage/power supply failure

LoB - output signalling low battery voltage

Above mentioned outputs should be connected with free alarm line on controller or on extension module and monitoring schedule should be enabled.

Diagram above shows only connections, which should be made inside the enclosure, between power supply module, controller module, I/O module, tamper switch and battery.

Detailed information about all parameters and terminals in APSAAT4 power supply are specified in the operating manual of the power supply on the website:

<http://www.aat.pl/pl/products/2930/APSAAT4>

8. Controller module installation and connections in housing

Controller and extension module (option) should be installed in a dedicated buffer power supply housing. Dedicated housing APSAAT4, designed for model KDH-KS3024-IP, is recommended.

Before installing controller module, 4 metal spacer bars (included) should be installed in bottom holes. Since controller modules have different sizes, number of holes are made at the bottom of housing. The base point for all models, which can be installed in this enclosure, is the hole located in upper left corner of controller module installation space (location is shown on previous page). The buffer power supply, mounted in this housing, has capacity of 5A. Power supply output is split and individually protected - for modules (0,9 A) and locks (4 A). This capacity allows connecting controller module, 2 or 4 readers and 2 or 4 electric locks (even electromagnetic locks with current consumption 500 mA). Housing is adapted to internal installation of 7Ah battery.

NOTE: If it's necessary to provide longer operation time for controller, separate supply power with 18Ah rechargeable battery should be connected to the battery cables derived from APSAAT4. To avoid the reverse charge current please install diode in series circuit. The manufacturer strongly discourages direct connection to the power supply in APSAAT4 battery with a larger capacity than 7Ah because it requires a larger charging current.

After installing module in the enclosure with screw kit, following connections should be made (shown on previous page):

- connect supply voltage output (AUX 1 12VDC) with controller terminals
- additional terminals on controller module supply socket can be connected to I/O module, according to figure on previous page.
- connect controller RS485 port, using 3-core signal wire, with corresponding port on I/O module, according to figure and terminals description on page 8
- install battery at the bottom of housing and connect dedicated wires (red (+) and black (-), coming from the left side of power supply module).
- connect housing tamper switch to free alarm line input (enable monitoring schedule in software - *Always enabled*)
- connect readers, locks, buttons and door status wires to terminals on controller edges
- connect cable with RJ45 connector to Ethernet socket, located in the upper left corner of the controller module. Other end of the cable should be connected to Ethernet network.
- connect mains power supply 230 VAC to electrical terminal block in the bottom part of housing (through existing fuse), in accordance with colors of wires, coming from the terminal block to the power supply

After finishing all connections, once again check, if they are all correct and only after this turn on the mains voltage 230 V and check if controller is working properly.

After turning on mains voltage, observe LED indicators on power supply module, controller and I/O module. 12V voltage presence indicators should first light up on power supply module, and then on controller (POWER LED) and I/O module.

Next, RUN diode on controller module and I/O module should start blinking. Thereafter, LEDs on readers should light up.

Housing is equipped with dismantled door, which can be disassembled for connecting wires, after disconnecting grounding wire. Housing can be closed with two screws, fastened on the right. Opening of the enclosure is monitored by tamper switch, which generates alarm, if it's not temporarily disabled by administrator, for service purposes.

9. Adding cards to controller memory without software

3000 series controllers have ability to add cards to the controller database, using connected standard reader, without connecting with management software.

It's very useful function on system commissioning and testing stage, because it allows fast and simple adding of cards with privileges. Using this method, up to 3000 cards can be added, all with administrator rights and working in 7/24h mode. After communicating controller with the software, at a further stage of installation, it is possible to remotely delete these cards, but they are not overwritten by cards added with the software. If we want to have uniform card database in entire system, obviously cards added with this method should be deleted and card database should be sent from the management software on PC. Function of adding cards with this method is enabled as default, but it can be disabled after connecting controller with the software. Adding cards using reader affects only database of controller, to which reader used for reading cards is connected. If system consists of more controllers, this procedure should be repeated individually for each controller.

Procedure for creating programming card:

1. Push the button *Mode*, located on the upper edge of controller and hold it for 3 seconds. Read any card in the reader - it will be programming card. To exit programming mode, push the button twice and wait for 30 seconds.

Procedure for adding cards to the controller memory:

1. Read programming card in the reader once. Entering to programming mode is indicated by blinking LED on the reader alternately, in red and green.
2. Read card, which should be added. LED on the reader will flash in red for 1,2 seconds. It indicates adding card. Read further cards, which should be added.
3. In order to finish procedure of adding cards read the programming card again or wait for 12 seconds.

Procedure for deleting cards from controller memory:

1. Read the programming card in the reader twice. Entering to programming mode is indicated by LED on the reader flashing green.
2. Read the card, which should be deleted. LED on the reader will flash in red for 1, 2 seconds. It indicates deleting card. Read further cards, which should be deleted.
3. In order to finish procedure of adding cards read the programming card again or wait for 12 seconds.

Procedure for deleting all cards from controller memory:

1. Read the programming card in the reader three times. Entering to programming mode is indicated by LED on the reader flashing green.
2. After 4 seconds read programming card again. All cards are deleted and reader will leave the programming mode.

 **KaDe**



AAT SYSTEMY BEZPIECZEŃSTWA Sp. z o.o.

431 Pulawska St, 02-801 Warsaw, phone: +48 22 546 05 46, fax: +48 22 546 05 01
www.aat.pl